

Pilot SCR5.5 Scroll Air Compressor



SCR Series Scroll Compressors



Instructions and Parts List

Dear Customer,

Thank you for choosing Pilot Air.

In order to get the best performance out of this product, please read this manual carefully.

To avoid incorrect operation of the equipment and possible physical risk to the operator, please read and strictly follow the instructions contained in this manual.

Note, these instructions are in addition to the safety rules that apply in the country where the air compressor is installed.

Before packing for shipment, each machine undergoes a rigorous test to ensure the absence of any manufacturing faults and to demonstrate that the device can perform all the functions for which it has been designed.

This manual must be maintained available in any moment for future references and it has to be intended as inherent part of the relevant machine.

Due to the continuous technical evolution, we reserve the right to introduce any necessary change without giving previous notice.

Should you experience any trouble, or for further information, please do not hesitate to contact us.

Best Regards,



PILOT AIR COMPRESSORS

<http://www.pilotair.com>

Phone: 1300 667 579

Email: service@pilotair.com.au / spares@pilotair.com.au

INDEX

GB

1	Safety	4
2	Specification Chart	6
3	Installation	7
4	Commission & Operation	9
5	Operation	10
6	Maintenance	11
7	Wiring Diagram	17
8	Warrant Terms and Conditions	18



Pressure vessels (air receivers) are a type of plant, and as such, **MAY** be required to be registered with the relevant statutory authority in your state. Regulations regarding plant registration vary from state to state. Check with your relevant government authority about plant registration.



Compressed air can be dangerous. **Never** point compressed air tools or equipment towards another person.



After use, drain all residual air pressure or engage outlet tap to prevent accidental discharge by children.



Keep clear of compressor pump during and after operation. Heat build up in the pump may cause burns to unwary.



Never operate the unit without factory fitted belt guard. (Belt Drive Models) or Pump Shroud (Direct Drive Models).



Never operate the unit with damaged or exposed electrical wiring.



Do not alter, adjust or remove any components on the unit without technical support from Pilot Air or an authorised Pilot Air agent.



Whenever transporting an air compressor, ensure all air is drained from the air receiver. There should be NO residual air pressure in the air receiver.

Specification Chart

	F.A.D		Motor Size		Max. Pressure		Noise Level	Dimensions			Weight
	L/Min	CFM	KW	HP	KPA	PSI	D(B) A	L	W	H	Kg
SCR2.2/ 240V	240	8.8	2.2 (240V)	3 (240V)	800	116	58	850	600	930	195
SCR2.2	240	8.5	2.2	3	800	116	58	850	600	930	199
SCR4	400	14.1	4	5.5	800	116	59	850	600	930	215
SCR5.5	600	21.2	5.5	7.5	800	116	65	850	600	930	240
SCR7.5	850	30.0	7.5	10	800	116	68	850	680	980	255

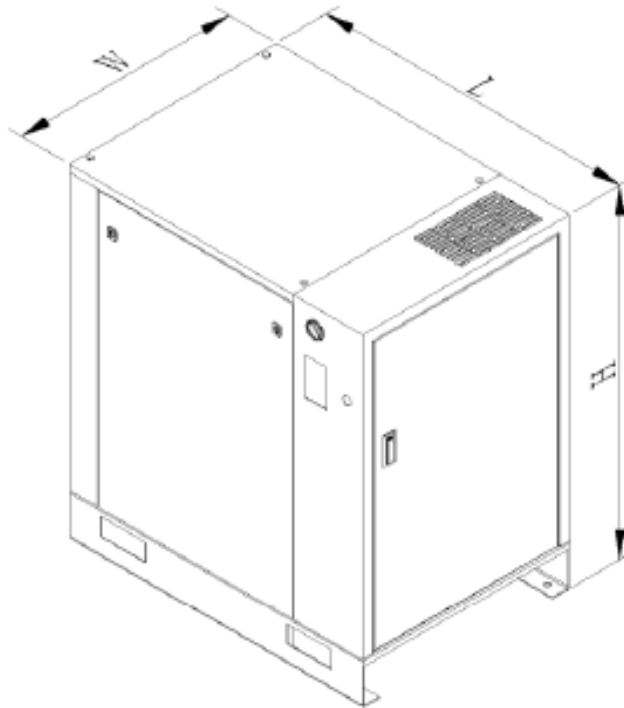

LOCATION

- An indoor installation is desirable with the seating ground able to bear the weight of the Air Compressor.
- Clean, well ventilated and free from corrosive or explosive vapor areas.
- Ensure a sufficient space around the compressor for the convenience of cooling and maintenance.
- Ensure the floor is levelled and of sufficient strength with adequate access for maintenance.
- Free space above the unit → Minimum of 1.5 M clearance.
- Free space on each side → Minimum of 1 M clearance.
- Place the unit on a flat surface and keep sufficient space for maintenance.

PRECAUTIONS BEFORE OPERATION

- The compressor should be operated under the supervising of authorized person.
- Never remove or modify the safety devices originally mounted on the unit.
- Never remove the covers while this unit is in operation
- Make sure the voltage and frequency of the power source are correct.
- All maintenance works have to be executed by authorized person.
- Never operate the compressor at higher Discharge pressure than those specified on the Compressor Nameplate pressure specification.
- Care needs to be exercised and the operation of the unit needs to be monitored in ambient conditions of 40 degrees or more

PANEL

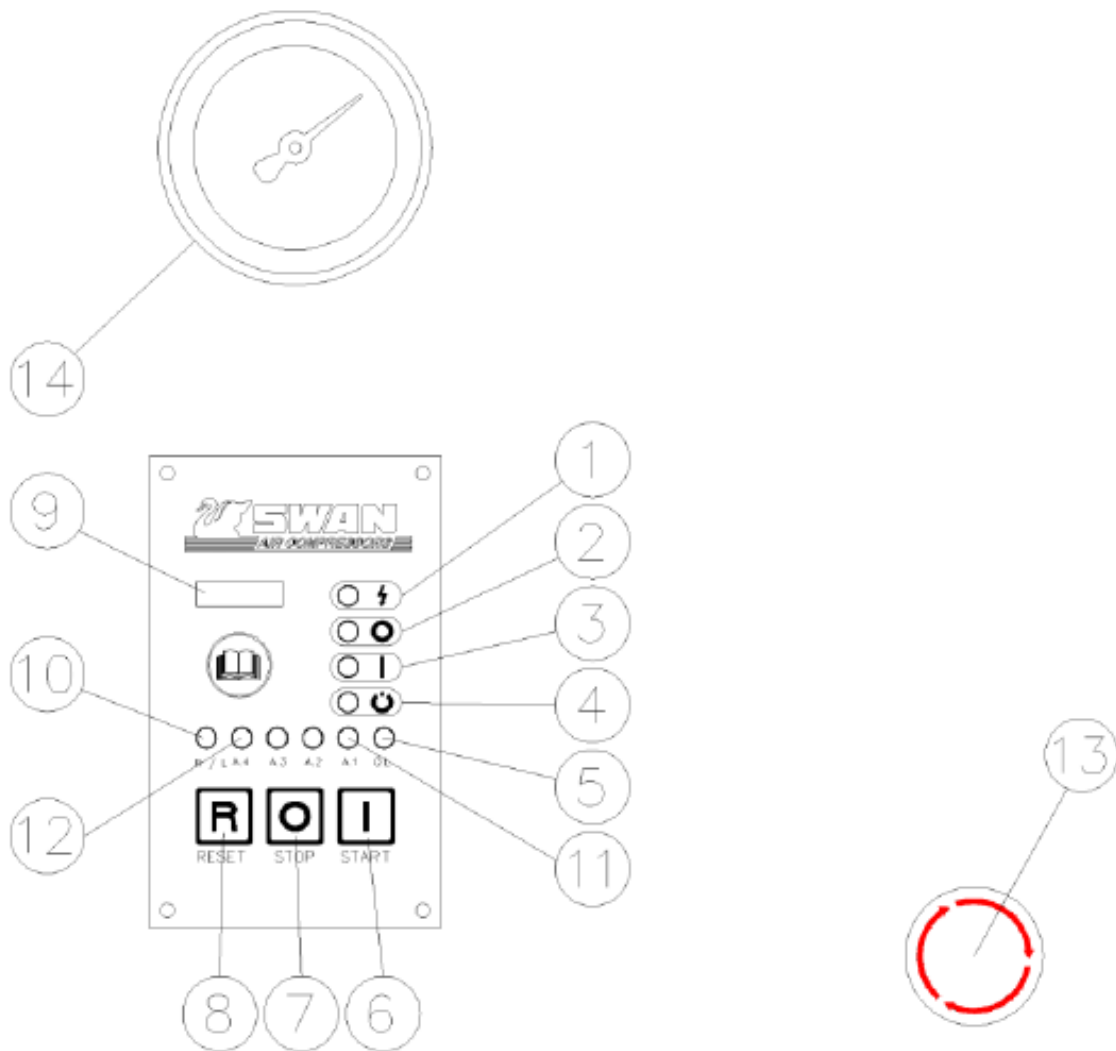

	NAME		NAME
1	Power Indicator	8	Reset
2	Stop Indicator	9	Hour Meter
3	Running	10	Remote / Local
4	Pressure	11	Phase Reversal
5	Overload	12	Over Temp.
6	START	13	Emergency
7	STOP	14	Pressure

When commissioning a new compressor or re-commissioning a compressor which has been out of service, the following operation recommendations should be followed.(The operator should have experience and be qualified.)

1. COMMISSIONING

A. PRIMARY CHECKS

1. Confirm that all the pipe and wire connections have been firmly connected, and the main power should be turned off.
2. Make sure all the electrical connections are correct.
3. Check the belts for tightness and adjust if required.
4. Remove the RED FICED PLATE.
5. Open the Stop Valve and switch on the main power.

B. CHECK BEFORE RUNNING

1. Confirm that the main Power Source and Earth have been connected well and the 3-phase voltage is correct.
2. (2) Press the START button and check rotation of Air end. The correct rotation is CCW looking from Air end pulley side(Follow the arrow label). If rotation is correct, go next process. If the Air end rotate in wrong direction, STOP immediately and exchange any two cables of power source.

ATTENTION: Incorrection direction of rotation is not allowable or the Air end will damaged seriously.

C. CHECK UNDER RUNNING

1. Switch power ON, press START.
2. Press STOP and CHECK immediately while there are noise or the vibrations of unit is getting seriously.
3. Check pressure is rising or not. If pressure does not rise, turn the unit off, check the Pressure Gauge, rotation of Air end and pressure pipe.
4. If the unit is running in normal status, close all the covers.

A. START

1. Switch the power on. Check the Power Indicator is on.
2. Open the Stop Valve and push the START button. Confirm pressure is rising at correct working pressure.

ATTENTION: It should be conducted commissioning procedure before starting the compressor which is not be used for a long period of time.

B. PRESSURE INDICATOR

1. When discharge pressure reaches the upper limit of Pressure Switch, the compressor stops and the Pressure Indicator is on.
2. When discharge pressure reaches the lower limit of Pressure Switch, the compressor starts and the Pressure Indicator is off.

C. SHUT-DOWN

1. Push the STOP button to stop the compressor.
2. In emergency situation, push the EMERGENCY STOP button.

ATTENTION: Before restart the unit, make sure all the problems have been rectified. And turn the EMERGENCY STOP 45° clockwise and then push the RESET button. Do not use EMERGENCY STOP in normal use or the equipment may be damaged.

D. RESET

1. When the compressor shuts down as the protective device or emergency stop, all the problems or faults should be resolved before pushing the RESET button and restart the unit.

ATTENTION: All the part and pipe in the compressor is at high temperature. DO NOT touch any part or pipe without any protection or cause serious injury.

MAINTENANCE PRECAUTIONS

- All maintenance works are to be executed by authorized person.
- Always use spare parts supplied by the original factory for replacement
- Please follow the following procedures before doing maintenance:
- Switch the Main Power Breaker to "OFF" position, and remove the fuse inside the control cabinet to disconnect the electric power to the control system
- Shut off the Stop Valve on the Air-outlet piping.
- Release all the compressed air inside the Compressor unit and make sure the Pressure Gauge reading is "ZERO".
- Only use the specified grease recommended by the original factory.
- Clean all oil sludge or dirt that may exist on the compressor unit and its surroundings before doing maintenance.
- Make sure to follow the instructions mentioned in this manual and all the relative components and safety devices are under normal situation.
- All the pressure gauges have to be inspected periodically. Replace them with new ones when they are abnormal.
- All the safety devices have to be inspected periodically and with inspection records.
- Always keep the inner parts of the compressor unit clean. Prevent from any foreign material or moisture flying into the inside of key components
- Keep moisture, high temperature, and dirty atmosphere away from the control boards.
- Do not modify or weld on the pressure vessel.
- After maintenance, make sure no any tools or rags left inside the compressor unit.
- Before running the compressor, make sure the motor rotating direction is correct.
- Never use combustible liquid to clean the Valve set and the Cooler.
- Carefully treat all the waste grease and waste water by following local
- Environmental Regulations.

ROUTINE MAINTENANCE

1. CLEAN

- Always keep the unit clean

2. RECORD

- 2.1. Write down daily operating pressure and temperature shown on the indicator together with ambient air temperature on a Maintenance Record Card. The reading should be taken when conditions are stable and the unit running on full load.
- 2.2. Keep a careful record of all servicing, repair and failure history. The record will become useful reference for future maintenance.

3. ELECTRICAL CONNECTIONS

- Check electrical connections regularly. Clean and tighten all connections and repair or replace cables before starting up.

4. LEAKAGE

- Check if any leakage in the compressor system.

5. BELT TENSION

- Check the belts for tightness and adjust it daily if necessary.

BELT MAINTENANCE

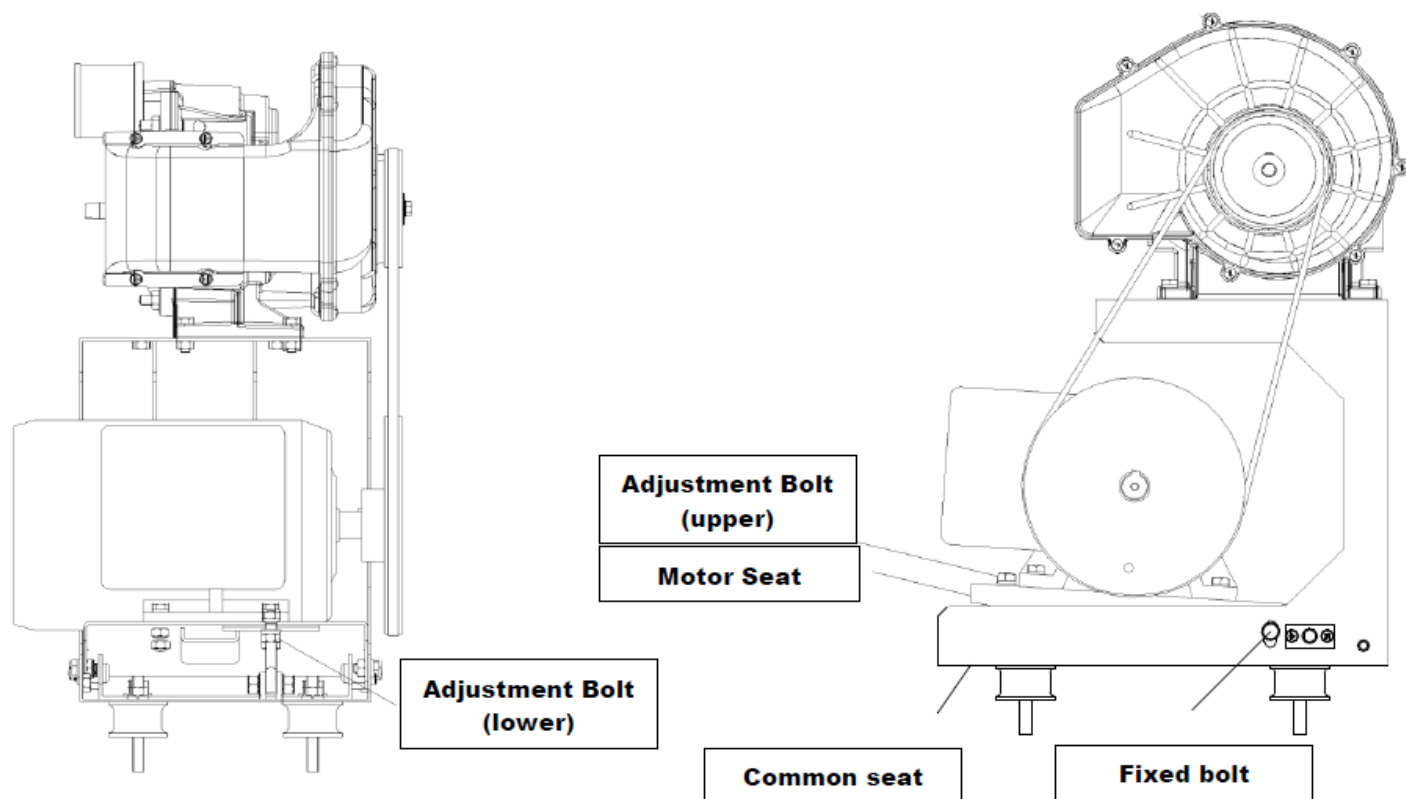

Figure 1

ADJUSTMENT BELT TENSION

1. Loosen the two fixed bolts on the side of common seat.
2. Screwing the adjustment bolt(lower) downward, and the motor seat goes down slowly until the belts reach the proper tension(see page 20).
3. Tighten the adjustment bolt(upper). Check the belt tension again then tighten the two fixed bolts on the side of common seat.

BELT REPLACEMENT

1. Loosen the two fixed bolts on the side of common seat.
2. Loosen the adjustment bolt (upper), and then screwing the adjustment bolt (lower) upward. The motor seat goes up slowly until the belts can be take off.
3. Make alignment by locating a steel ruler between pulley of Air end and motor, and the clearance between two pulley below 1.0 mm.
4. Replace all belts.
5. Follow steps A. (ADJUSTMENT BELT TENSION), C. (BELT TENSION MEASUREMENT)

BELT TENSION MEASUREMENT

Model	W Deflection Force (Kg)	δ Deflection (mm)
SKR-02C	6	3.6
SKR-04C	10	3.6
SKR-06C	7	3.4

Check deflection force with tensionmeter (see Figure 2) until every belt reaches to deflection value as chart

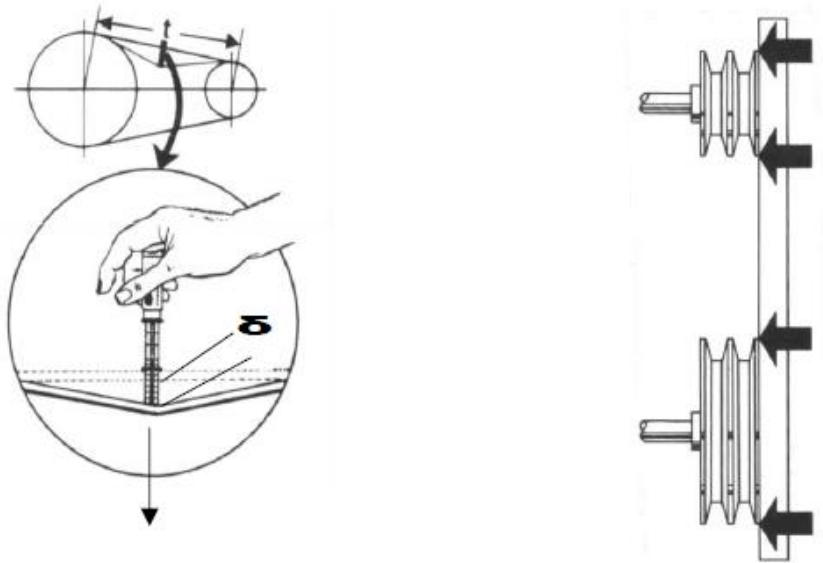

ENCLOSURE FILTER

- Fitted on the cover, the pre-filter is used to screen air before intake filter. Daily check is required. If any dust accumulated, please follow the steps as below:
 - Remove the dust-preventive cover.
 - Clean with compressed air or neutral detergent and water then dry and install the cover back.

INTAKE FILTERS

- According to the Air end Maintenance Schedule, clean with compressed air or replace with a new element if necessary.
- **ATTENTION:** Never clean filter element with solvents or water.

COOLER

- After running for a period of time, cooler fins might be covered with dust so as to reduce cooling efficiency, causing higher Discharge temperature.
- Clean with compressed air or neutral detergent and water if necessary.

ELECTRICAL SYSTEM

- Check all the electrical connections are firmly connected。

Troubleshooting

Problem		Possible Cause	Remedy
Compressor fails to start	Silent Motor	Cables loose	Check / Tighten
		Magnetic contactor fault	Check / Replace
		Panel fault	Check / Replace / Repair
		Motor failure	Check / Replace / Repair
		Phase reversal	Exchange any two cables
		Protection switch be actuated	Check / Reset
		Blown fuses	Check / Replace
	Motor buzz	Motor failure	Check / Replace / Repair
		Failure of air end	Disassemble and Repair
		Low voltage	Check / Improve power supply
Cable improper		Check / Replace	
Over-current	Low voltage	Check / Improve power supply	
	Hight discharge pressure	Reset pressure switch	
	Failure of air end	Disassemble and Repair	
	Motor failure	Check / Replace / Repair	
Low current	Low discharge pressure	Reset pressure switch	
	Air end rotates backward	Change phase	
	Clogged intake filter	Clean or Replace	

Troubleshooting

Problem	Possible Cause	Remedy
High discharge temperature	High ambient temperature or bad ventilation	Improve installation environment & ventilation
	Clogging of cooler fins or enclosure filter	Clean
Safety valve activated	Failure of safety valve	Replace
	Failure of pressure switch	Check / Replace
Discharge pressure does not increase	Air leaks from pipes	Check / Replace / Repair
	Clogged intake filter	Clean / Replace
	Failure of pressure switch	Reset / Replace
	Air consumption exceeds compressor's	Recalculate air
	Air end rotates backward	Change phase
Abnormal sound and vibration	Failure of air end	Disassemble and Repair
	Air end rotates backward	Change phase
	Covers unlocks	Check and lock
	Loosen bolts	Check and tighten
	Motor failure	Check / Replace / Repair
	Belt slips	Check tension and readjust
	Unbalanced cooling fan	Check / Clean
Compressor stops and the air end rotates backward	Failure of Check valve	Replace / Repair
Overload relay actuated	Wrong setting	Reset
	High Discharge pressure	Check / Replace / Reset
	Failure of air end	Disassemble and Repair
	Low voltage	Check / Improve power supply
	Motor failure	Check / Replace / Repair
	Overload relay failure	Replace

Warranty

Pilot Air Compressors Pty Ltd **manufactured goods - 1 Year Warranty and 3 Year Warranty (where applicable)**

(DATE)

Pilot Air Compressors Pty Ltd (**Pilot Air**) warrants to the first purchaser of goods (manufactured by it) (Product) from Pilot Air and the last purchaser prior to installation that, subject to compliance with the Conditions of Warranties below that:

1. For a period of 12 months from the date of purchase, the Product will be free from defects due to defective factory workmanship or materials; and
2. For a period of 12 months from the date of purchase that Pilot Air branded accessories supplied by Pilot Air will be free from defects due to defective factory workmanship or materials.
3. The compressor pump only (and excluding all other components of the unit) in the following units:
 - a. TM Series Units
 - b. Classic K Series Units
 - c. Petrol Industrial Series Units
 - d. Three Phase Industrial Series Units

will be free from defects due to defective factory workmanship or materials for a period of 3 years from the date of purchase.

4. The 'DCR', 'PAC' and 'FP' Series of Rotary Screw type compressors will be free from defects due to defective factory workmanship or materials for 3,000 working hours in the first 12 months from the date of purchase. This warranty is extended to a period of 2 years for the air end of the DCR PAC and FP Series Compressors.
5. Where compressors are powered with either petrol or diesel engines, the engine only is subject to the warranty provided by the manufacturer of the engine.
6. Non-Pilot Air accessories (meaning accessories which are not Pilot Air manufactured and branded) which are supplied by Pilot Air are not covered by this warranty. Purchasers are referred to the individual manufacturer's warranty. Purchasers can request a copy of the applicable warranties by contacting Pilot Air using the contact details below.

Warranty

Conditions of Warranties

The warranties specified herein are subject to the following conditions:

- (a) Pilot Air will not be liable for a breach of any of its warranties unless the Claimant provides proof of purchase of the Product and makes a written claim to Pilot Air at the address set out below, either within 30 days after the defect would have become reasonably apparent, or if the defect was reasonably apparent prior to installation, then the claim must be made prior to installation;
- (b) The warranties are not transferable;
- (c) The Product must be installed, operated, maintained and serviced strictly in accordance with the relevant Pilot Air literature current at the time of installation and must be installed in conjunction with the components or products specified in the Pilot Air literature. To obtain copies of such literature go to www.pilotair.com.au or telephone Pilot Air on (02) 9648 3099;
- (d) If the claimant chooses to rely upon any warranty specified herein the claimant's sole remedy under the warranty for breach of the warranty is (at Pilot Air's option) that Pilot Air will either supply replacement Product, rectify the affected Product or pay for the cost of the replacement or rectification of the affected product;
- (e) In the circumstances where the guarantees under the Australian Consumer Law do not apply in respect to the purchase of its Products, Pilot Air will not be liable for any losses or damages (whether direct or indirect) including property damage or personal injury, consequential loss, economic loss or loss of profits, arising in contract or negligence or howsoever arising. Without limiting the foregoing, Pilot Air will not be liable for any claims, damages or defects arising from misuse of the Product, inadequate maintenance and storage of the Product, repairs rendered necessary or arising from the use of non-genuine Pilot Air parts in the product, normal wear and tear maintenance of the Product, deterioration of any part of the Product due to normal wear and tear, work performed on the Product other than by an authorised Pilot Air service technician or their agent, use of the Product for any purpose other than which it was intended to be used, use of the Product after essential parts and accessories have been removed, operating the Product continuously under excessive load, and if the serial/model label has been removed or obscured on the Product;
- (f) In circumstances where the guarantees under the Australian Consumer Law do not apply in respect to the purchase of its Product/s: all warranties, conditions, liabilities and obligations other than those specified herein are excluded to the fullest extent allowed by law.
- (g) Parts repaired or replaced under any warranty specified herein are warranted only for the remaining period of the original warranty period.

Warranty

- (h) All defective parts that are the subject of a claim under any warranty specified herein become the property of Pilot Air.
- (i) The warranties specified herein do not apply to the following parts or conditions and cannot be relied upon in the situation whereby:
 - i) any Pilot Air product or part has been subject to misuse, negligence, accidental damage, improper or inadequate use, inadequate maintenance or improper storage or been operated under unusual conditions or continuously under excessive load;
 - ii) the defect has been caused by the use of non-genuine Pilot Air parts;
 - iii) the defect or deterioration was due to normal use, fair wear and tear and exposure, unless due to any defect in material or workmanship;
 - iv) work was undertaken on any Pilot Air product or part by an unauthorised Pilot Air agent;
 - v) the serial /model label has been removed from any Pilot Air product or part;
 - vi) normal maintenance items/parts including valves and piston rings
- (j) Warranty repairs on all 240 Volt and portable units shall be on a back to base basis that the Claimant is required to return the Product to the nominated warranty agent as advised by Pilot Air, provided that such costs are not significant;
- (k) The replacement or repair of any defective part or correction of operating faults under any warranty specified herein is to be made only after Pilot Air, or its authorised representative, have examined the unit to their satisfaction, with their decision being final.
- (l) In the circumstances where Pilot Air accepts or it is determined by Pilot Air that the claimant has a valid claim under this warranty, and subject to paragraph (m) below, Pilot Air will bear all of the claimant's reasonable and proximate expenses incurred as a result of claiming under this warranty. The claimant is to inform Pilot Air in writing to the address identified below within 21 days from when the claimant first makes a claim under this warranty of all such claims and expenses and provide it with copies of all receipts and invoices where relevant before any reimbursement is made by Pilot Air to the claimant. The claimant is responsible for all other costs of claiming under this warranty.
- (m) Pilot Air will not be responsible for any courier, transport or freight related costs whatsoever associated with the return to it of any defective Product that have not first been approved by it. Pilot Air reserves the right to first inspect any defective Product and decide how, if at all, the defective Product is to be returned to it. Any unapproved courier, transport or freight related costs will be to the claimant's account.

Warranty

Important Note:

If you acquire goods from Pilot Air as a consumer according to the Australian Consumer Law, our goods come with guarantees that cannot be excluded under the Australian Consumer Law. You are entitled to a replacement or refund for a major failure and for compensation for any other reasonably foreseeable loss or damage. You are also entitled to have the goods repaired or replaced if the goods fail to be of acceptable quality and the failure does not amount to a major failure.

Any rights a consumer may have under any warranty specified herein are in addition to other rights and remedies of a consumer under a law in relation to the goods to which these warranties relate. Nothing in this document shall exclude or modify any legal rights a customer may have under the Australian Consumer Law or otherwise which cannot be excluded or modified at law.

Contact details if you wish to make a claim under any warranty specified herein:

For more information or to make a claim under any warranty specified herein please telephone Pilot Air on (02) 9648 3099, email Pilot Air via our website: <http://www.pilotair.com.au> or write to Pilot Air at:

Pilot Air Compressors Pty Ltd 115 Beaconsfield Road
Silverwater NSW 2128