

NGS ROTARY SCREW AIR COMPRESSOR



Installation, Maintenance, and Operation Manual

Dear Customer,

Thank you for choosing Pilot Air.

To get the best performance out of this product, please read this manual carefully.

To avoid incorrect operation of the equipment and possible physical risk to the operator, please read and strictly follow the instructions contained in this manual.

Note, these instructions are in addition to the safety rules that apply in the country where the air compressor is installed.

Before packing for shipment, each machine undergoes a rigorous test to ensure the absence of any manufacturing faults and to demonstrate that the device can perform all the functions for which it has been designed.

This manual must be kept available for future references.

Due to the continuous technical evolution, we reserve the right to introduce any necessary change without giving previous notice.

Should you experience any trouble, or for further information, please do not hesitate to contact us.

Best Regards,



<http://www.pilotair.com.au>

Phone: 1300 667 579

Email: service@pilotair.com.au / spares@pilotair.com.au

DECLARATION OF CONFORMITY

The following declaration is attached to the compressor in original copy.

All identification data: manufacturer, model, code and serial number are stamped on EC label.

For any request for copies it is ESSENTIAL to provide ALL the data stamped on EC label.

<p>IT - Dichiaro sotto la sua esclusiva responsabilità, che il compressore d'aria qui di seguito descritto è conforme alle prescrizioni di sicurezza delle direttive: 2006/42/CE, 2006/95/CE, 2004/108/CE, 2009/105/CE, EN 1012-1, EN 60204-1, EN 61000-6-3/4.</p>	<p>SI - Na lastno odgovornost izjavljam, da je spodaj opisani zračni kompresor v skladu z varnostnimi predpisi, ki veljajo za stroje 2006/42/EU, 2006/95/EU, 2004/108/EU, 2009/105/EU, EN 1012-1, EN 60204-1, EN 61000-6-3/4.</p>
<p>GB - Declares under its sole responsibility that the air compressor described below complies with the safety requirements of directives: 2006/42/EC, 2006/95/EC, 2004/108/EC, 2009/105/EC, EN 1012-1, EN 60204-1, EN 61000-6-3/4</p>	<p>HU Kizárólagos felelőssége tudatában kijelenti, hogy a lent megnevezett légsűrítő megfelel a 2006/42/EK, 2006/95/EK, 2004/108/EK, 2009/105/EK, EN 1012-1, EN 60204-1 és EN 61000-6-3/4 irányelvek rendelkezéseinek</p>
<p>FR - Déclare sous son entière responsabilité que le compresseur d'air décrit ci-après est conforme aux prescriptions de sécurité des directives : 2006/42/CE, 2006/95/CE, 2004/108/CE, 2009/105/CEE, EN 1012-1, EN 60204-1, EN 61000-6-3/4..</p>	<p>CZ - prohlašuje s plnou odpovědností, že uvedený vzduchový kompresor vyhovuje bezpečnostním požadavkům směrnic: 2006/42/ES, 2006/95/ES, 2004/108/ES, 2009/105/ES, EN 1012-1, EN 60204-1, EN 61000-6-3/4.</p>
<p>DE - erkläre unter Ihrer alleinigen Verantwortung, daß der In Folge beschriebene Luftkompressor den Sicherheitsvorschriften der Richtlinien: 2006/42/EG, 2006/95/EG, 2004/108/EG, 2009/105/EG, EN 1012-1, EN 60204-1, EN 61000-6-3/4..</p>	<p>SK - Zodpovedne vyhlasuje, že uvedený vzduchový kompresor zodpovedá bezpečnostným požiadavkám smerníc: 2006/42/ES, 2006/95/ES, 2004/108/ES, 2009/105/ES, EN 1012-1, EN 60204-1, EN 61000-6-3/4.</p>
<p>ES - Declaro bajo su exclusiva responsabilidad que el compresor de aire descrito a continuación responde a las prescripciones de seguridad de las directivas : 2006/42/CE, 2006/95/CE, 2004/108/CE, 2009/105/CEE, EN 1012-1, EN 60204-1, EN 61000-6-3/4</p>	<p>RU - Заявляет под свою полную ответственность, что нижеописанный воздушный компрессор соответствует требованиям безопасности согласно директивам 2006/42/EC, 2006/95/EC, 2004/108/EC, 2009/105/EC, EN 1012-1, EN 60204-1, EN 61000-6-3/4</p>
<p>PT - Declaro sob a sua exclusiva responsabilidade que o compressor de ar descrito a seguir está em conformidade com as prescrições de segurança das directivas: 2006/42/CE, 2006/95/CE, 2004/108/CE, 2009/105/CEE, EN 1012-1, EN 60204-1, EN 61000-6-3/4</p>	<p>NO - Erklærer under eget ansvar at luftkompressoren her beskrevet er i overensstemmelse med sikkerhetsforskriftene i direktivene: 2006/42/EC, 2006/95/EC, 2004/108/EC, 2009/105/EC, EN 1012-1, EN 60204-1, EN 61000-6-3/4..</p>
<p>NL - Verklaart onder zijn eigen verantwoordelijkheid dat de hieronder beschreven luchtcompressor in overeenstemming is met de veiligheidsvoorschriften van de richtlijnen: 2006/42/EG, 2006/95/EG, 2004/108/EG, 2009/105/EG(ex 87/404/EEG), EN 1012-1, EN 60204-1, EN 61000-6-3/4</p>	<p>TR - Tek sorumluluk kendisinde olmak üzere, aşağıda anlatılan hava kompresörünün şu direktiflerin güvenli gerekliliklerine uygun olduğunu beyan eder/ederiz: 2006/42/EC, 2006/95/EC, 2004/108/EC, 2009/105/EC, EN 1012-1, EN 60204-1, EN 61000-6-3/4</p>
<p>DK - Forsikrer på eget ansvar, at luftkompressoren, der beskrives nedenfor, er i overensstemmelse med sikkerhedsforskriftene i direktivene: 2006/42/EC, 2006/95/EC, 2004/108/EC, 2009/105/EC, EN 1012-1, EN 60204-1, EN 61000-6-3/4..</p>	<p>RO - Declaro pe propria raspundere ca, compresorul de aer denumit in continuare, este in conformitate cu cerintele de securitate cuprinse in directivele: 2006/42/CE, 2006/95/CE, 2004/108/CE, 2009/105/CE, EN 1012-1, EN 60204-1, EN 61000-6-3/4</p>
<p>SE - Forsäkrar under eget ansvar att den luftkompressor som beskrivs följande är i överensstämmelse med säkerhetsföreskrifterna i EU-direktiv: 2006/42/EG, 2006/95/EG, 2009/105/EG, EN 1012-1, EN 60204-1, EN 61000-6-3/4..</p>	<p>BG - Декларира на собствена отговорност, че въздушният компресор описан по-долу е в съответствие с изискванията на директивата за безопасност: 2006/42/EC, 2006/95/EC, 2004/108/EC, 2009/105/EC, EN 1012-1, EN 60204-1, EN 61000-6-3/4</p>
<p>FI - vakuuttaa, että seuraavassa esitelly ilmakompressorin vastaa alla lueteltujen direktiivien turvallisuusvaatimuksia: 2006/42/EC, 2006/95/EC, 2004/108/EC, 2009/105/EC, EN 1012-1, EN 60204-1, EN 61000-6-3/4..</p>	<p>RS - Izjavljuje pod punom odgovornošću da je dole opisan kompresor vazduha u skladu sa sigurnosnim zahtevima sledećih Direktiva: 2006/42/EZ, 2006/95/EZ, 2004/108/EZ, 2009/105/EZ, EN 1012-1, EN 60204-1, EN 61000-6-3/4</p>
<p>GR - Δηλώνω με αποκλειστική δική της ευθύνη, ότι ο συμπιεστής αέρα που περιγράφεται παρακάτω ανταποκρίνεται στις προδιαγραφές ασφαλείας των οδηγιών: <input type="checkbox"/> 2006/42/ΕΚ, 2006/95/ΕΚ, 2004/108/ΕΚ, 2009/105/ΕΚ, EN 1012-1, EN 60204-1, EN 61000-6-3/4.</p>	<p>LT - Su visa atsakomybe pareiškia, kad žemiau aprašytas oro kompresorius atitinka saugumo direktyvų 2006/42/ES, 2006/95/ES, 2004/108/ES, 2009/105/ES, EN 1012-1, EN 60204-1, EN 61000-6-3/4</p>
<p>PL - Deklaruję pod pełną własną odpowiedzialność, że opisana niżej sprężarka powietrzna odpowiada wymaganiom bezpieczeństwa zawartym w Dyrektywach 2006/42/EC, 2006/95/EC, 2004/108/EC, 2009/105/EC, EN 1012-1, EN 60204-1, EN 61000-6-3/4</p>	<p>EE - Avaldab enda täieliku vastutusega, et edaspidi kirjeldatud õhukompressor vastab ohutuse nõudmistele direktiividele 2006/42/CE, 2006/95/CE, 2004/108/CE, 2009/105/CE, EN 1012-1, EN 60204-1, EN 61000-6-3/4.</p>
<p>HR - Izjavljuje pod punom odgovornošću da je dolje opisan kompresor zraka u skladu sa sigurnosnim zahtjevima sljedećih direktiva 2006/42/EC, 2006/95/EC, 2004/108/EC, 2009/105/EC, EN 1012-1, EN 60204-1, EN 61000-6-3/4</p>	<p>LV - Apliecinā zem savas pilnīgas atbildības, ka apakšā aprakstītais gaisa kompresors atbilst direktīvu, 2006/42/EC, 2006/95/EC, 2004/108/EC, 2009/105/EC, EN 1012-1, EN 60204-1, EN 61000-6-3/4..</p>

Table of Content

Installation, Maintenance, and Operation Manual	2
Chapter 1: Safety Regulations	5
Inverter Precautions	8
Chapter 2: Screw Air Compressor Installation	9
1. Installation	9
2. Foundation	10
3. General Electrical Specifications and Safety Standards	10
Chapter 3: System Process	11
Safety Protection System and Warning Devices	12
1. Motor Overload Protection	12
2. Excessive Exhaust Temperature Protection	12
3. Alarm Devices	13
Control System and Electrical Circuits	13
1. Control System	13
2. Electrical Circuits	14
Chapter 4 Controller Basic Operation	17
1. Button Explanation	17
2. Indicator instructions	17
3. Display of status and operations	18
Chapter 5: Operation	20
1. Trial Run, Startup, and Shutdown	20
2. Pre-Startup Checks	20
3. Precautions During Operation	21
4. Handling Method for Long-Term Shutdown	21
Chapter 6: Maintenance and Inspection	23
1. Lubricating Oil Specifications and Maintenance	23
2. Pressure System Adjustment	23
3. Recommended Maintenance Schedule	25
Chapter 7: Troubleshooting	26
1. Troubleshooting Guide	26
2. Screw Air Compressor Operation Log Sheet	30
Chapter 8: Spare Parts	31
Chapter 9: Warranty Terms and Conditions	32

Chapter 1: Safety Regulations

READ THIS PAGE CAREFULLY BEFORE PERFORMING ANY OPERATION ON THE COMPRESSOR

GENERAL WARNINGS

The rotary screw compressors are destined for arduous and continuous industrial use. They are particularly well-suited for applications in industries where a high rate of air consumption is required for extended periods.

The compressor must be used exclusively as indicated in this manual, which must be kept carefully in an easily accessible place known to everyone, as it must remain with the machine for its entire duration.

The company in which the compressor is to be installed must appoint a person in charge of the compressor itself. Controls, adjustments, and maintenance interventions are under his responsibility: if this person must be replaced, the substitute must read the user and maintenance manuals and any notes regarding technical and maintenance interventions carried out up to this time.

SYMBOLS USED IN THE MANUAL

Several symbols have been used in the manual to highlight dangerous situations, provide practical advice, or convey simple information. These symbols are found at the side of a text, at the side of a figure or at the top of a page (in this case, they refer to all subjects considered on the entire page).

Pay attention to the symbols' meanings.



ATTENTION!

Highlights an important description regarding technical interventions, dangerous conditions, safety warnings, advice and/or very important information.



REMOTE VOLTAGE!

It is compulsory to deactivate the electric power supply to the machine before carrying out any interventions on the machine.



MACHINE AT STANDSTILL!

Every operation highlighted by this symbol must only be carried out with the machine at a standstill.



SPECIALISED STAFF!

All interventions highlighted with this symbol must be carried out exclusively by a specialised technician.

Safety Regulations

READ THIS PAGE CAREFULLY BEFORE PERFORMING ANY OPERATION ON THE COMPRESSOR

SYMBOLS USED ON THE COMPRESSOR

Several different labels are applied to the compressor. Their function is primarily to highlight any hidden dangers and to indicate correct behaviour during the use of the machine or in particular situations.

Warning symbols



High temperature risk



Electric shock risk



Risk from hot or dangerous gases in the work area



Pressurised container



Moving mechanical parts



Maintenance in progress



Machine with automatic start-up

Prohibition symbols



Do not open hatches when the machine is functioning



If necessary, always use the emergency stop button and not the line isolating switch



Do not use water to put out fires on electrical appliances

Obligation symbols



Carefully read the user instructions

Safety Regulations

READ THIS PAGE CAREFULLY BEFORE PERFORMING ANY OPERATION ON THE COMPRESSOR

TO DO:

- Ensure that the mains voltage matches the voltage indicated on the CE plate, and use cables of suitable cross-section for electrical connections.
- Always check the oil level before starting the compressor.
- Be familiar with emergency stop control and all other controls.
- Unplug the connector before any maintenance work, to avoid accidental start.
- Ensure that all parts have been correctly reassembled after any maintenance work.
- Keep children and animals away from the working area to avoid injuries from devices connected to the compressor.
- Ensure that the working environment temperature ranges between +2 and +45 °C. Compressor working temperature shall range from 70 to 85 °C (room temperature 20-25°C). Lower temperatures may cause condensate to accumulate inside the oil separator tank (within the compressor).
Check for condensate and, if necessary, drain it (see maintenance).
- The compressor should be installed and operated in a non-explosive environment.
- Allow at least 80 cm between the compressor and the wall to ensure free airflow to the fan.
- Press the emergency button on the control panel only when necessary, to avoid possible damage to people or the compressor.
- When calling for technical assistance and/or advice, always mention the model, code and serial number indicated on the CE plate.
- Always follow the maintenance schedule specified in the user's guide.

DO NOT:

- Do not touch the inner parts or pipes, as they are very hot during compressor operation and remain hot for some time after the compressor stops.
- Do not position flammable materials close to or on the compressor.
- Do not move the compressor when the tank is under pressure.
- Do not operate the compressor if the power cable is damaged or defective, or if the connection is unstable.
- Never aim the air jet at people or animals.
- Do not allow unauthorised personnel to operate the compressor; provide all required instructions.
- Do not hit fans with blunt objects, as they might break during compressor operation.
- Never operate the compressor without an air filter.
- Do not tamper with safety and adjusting devices.
- Never operate the compressor when doors/panels are open or removed.
- Do not strike the fans with contusive or metallic objects, as they could cause sudden breakage while in use.
- Do not allow the compressor to function without the filter and/or air pre-filter.
- Do not tamper with safety and adjustment devices.

Inverter Precautions

1. Do not touch the heat sink fins and inverter when they are hot. Otherwise, you may get burned.
2. Do not arbitrarily change the inverter's factory-set parameters. Improper changes may damage the inverter.
3. Do not touch the inverter's wiring terminals; they carry high voltage. Touching them may cause an electric shock.
4. Before inspection or maintenance, the main power circuit must be cut off, and you must ensure the charge indicator light is off. It is dangerous to perform any work while residual voltage remains in the inverter's capacitors.
5. Only qualified personnel are allowed to perform inspections, repairs, or part replacements. Remove all metal objects (such as watches, bracelets, etc.) beforehand, and use insulated tools to prevent electric shock.
6. The inverter is equipped with a DC reactor as standard. When a radio or other electronic device is installed nearby, please install a filter on the input power side.
7. Failure to follow these rules may cause electric shock. Our company reserves the right to modify and improve products and is not responsible or obligated to make corresponding modifications and improvements to products already shipped.

Chapter 2: Screw Air Compressor Installation

1. Installation

- a. The foundation should be built on hard soil or concrete. Before installation, the foundation surface must be at ground level to avoid vibration of the air compressor.
- b. Before installation, check that the packaging box surface is intact and undamaged, and that the unit is undamaged. After unpacking, the unit's handling and installation must be carried out strictly in accordance with the relevant handling precautions. There are two forklift holes under the unit's base. When forklifting, place wooden blocks under the unit to prevent the forklift from crushing the unit's door panels (see figure). If you use slings, always use a spreader bar. The spreader bar can offset the side pressure generated by the slings pressing against the cabinet.



Safety Note: It is not advisable to pad protective materials between the slings and the unit's acoustic hood during loading and unloading. When lifting, the slings will crush the top side door panels of the unit.

- c. The selection of the air compressor installation site is most easily overlooked. Often, after purchasing the air compressor, it is placed in random places, piped up, and put into use immediately without prior planning. Little do they know that such a hasty result can lead to future compressor failures, difficult maintenance, and poor compressed air quality. Therefore, choosing an appropriate installation site is one of the prerequisites for the correct use of the air compressor system
- d. A wide, well-lit place is necessary to facilitate compressor operation, control, and maintenance.
- e. The air should have low relative humidity, little dust, and clean air, with good ventilation.
- f. The ambient temperature must be below 45°C. If the ambient temperature is too high, the compressor's output air will be lower
- g. If the factory environment is poor, with much dust, etc., pre-filtration equipment must be added to maintain the service life of the air compressor system components.
- h. Reserve access pathways and install overhead cranes (especially needed for high-power air compressors) to facilitate maintenance.
- i. Reserve maintenance space. The distance between the air compressor & the wall should be at least 1m.
- j. The distance between the top of the air compressor and the ceiling should be more than 1m.

Chapter 2: Screw Air Compressor Installation

2. Foundation

- a. The foundation should be built on hard soil or concrete. Before installation, the foundation surface must be at ground level to avoid vibration of the air compressor.
- b. If the air compressor is installed upstairs, vibration isolation must be installed to prevent vibration from transmitting downstairs or causing resonance, which poses safety hazards to both the air compressor and the building.
- c. Screw air compressors produce little vibration, so no special foundation is needed, but the ground on which they are placed must be flat, and the subsoil must not be soft soil.

3. General Electrical Specifications and Safety Standards

Select the appropriate power cable cross-section and terminals based on the air compressor's power rating. Do not use cables that are too small; the power cable may overheat, burn out, and pose other dangers.

- a. It is best for the air compressor to use a separate power system, especially to avoid parallel use with other systems with different power consumption. If used in parallel, it may overload the air compressor due to excessive voltage drop or three-phase current imbalance, triggering the protection device to trip. High-power air compressors must pay special attention to this.
- b. Install an appropriate NFB (No-Fuse Breaker) sized to the air compressor's power rating to maintain the safety of the power system and the compressor during maintenance.
- c. When wiring the air compressor, the power supply must be confirmed to be correct.
- d. The ground wire for the motor or system should be reliably grounded in accordance with relevant regulations, and it must not be connected to the air delivery pipe.
- e. Normally, for a three-phase AC motor, overload operation should not exceed the rated current by more than 3%. If the three-phase current is unbalanced, the ratio of the lowest phase current to the highest phase current must not exceed 5%. At the same time, if there is a voltage drop, it must not be less than 5% of the rated voltage.
- f. The air compressor must have a ground wire connected to earth to prevent electrical hazards caused by leakage.

Chapter 3: System Process

Screw Compressor System Flow Diagram

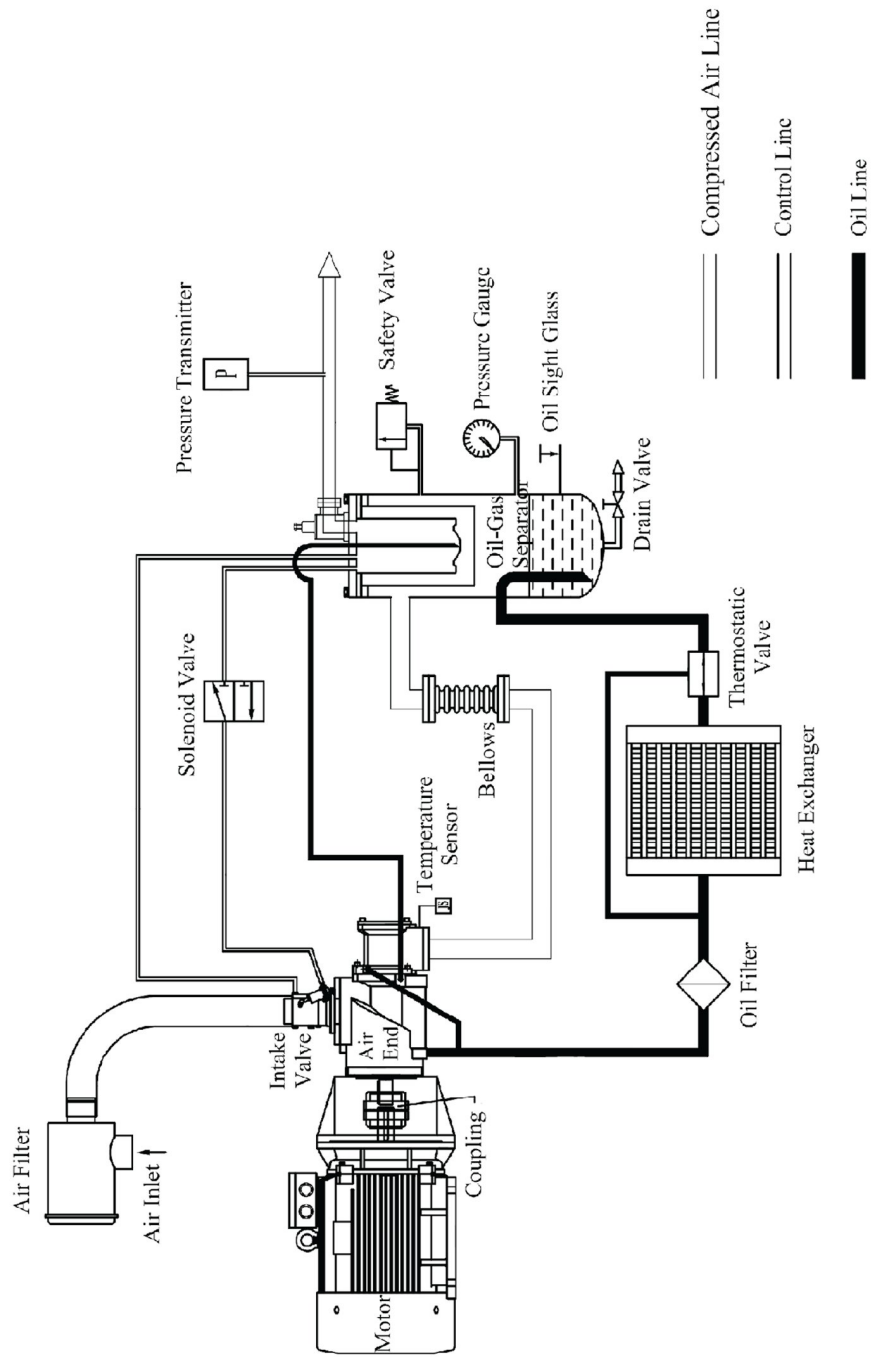

Safety Protection System and Warning Devices

1. Motor Overload Protection

There are two main motors in the air compressor system: one drives the compressor element, and the other drives the cooling circulation fan. Under normal conditions, the operating current of the motors does not exceed 3% of the rated current (except for factors such as voltage drop, three-phase imbalance, etc.). When the motor operating current exceeds the upper limit set by the controller's protection device, the overcurrent protection device will automatically cut off the main power, and the air compressor will shut down. At this time, the overload must be identified and the fault corrected before manually resetting the compressor. Otherwise, the air compressor cannot be restarted.

Common causes of motor overload:

1. Human operational error, such as self-adjusting exhaust pressure, improper system adjustment.
2. Mechanical failure: such as internal motor loss, single-phase operation of the motor, safety valve failure, system setting failure, oil-air separator blockage, etc.
3. Power supply failure: such as excessive voltage drop, three-phase imbalance, etc.
4. If a motor overload fault alarm is detected during operation, contact the manufacturer immediately to send personnel for inspection and accurately determine the cause. Otherwise, it may cause the motor windings to burn out and be damaged!

2. Excessive Exhaust Temperature Protection

The maximum exhaust temperature set by the system is 110°C. If it exceeds 110°C, the system automatically cuts off the power to the electric motor, and the air compressor shuts down. There are many reasons for excessively high exhaust temperatures, but the most common is poor heat dissipation from the oil cooler. For air-cooled oil coolers, if the cooling fins are clogged with dust, preventing cool air from freely passing through the cooler, the lubricating oil temperature will gradually rise, leading to a high-temperature shutdown. Therefore, low-pressure air should be used at regular intervals to remove dust from the cooling fins. If the clogging on the fins cannot be blown clean, it is best to clean them with cleaning fluid or solvent.

In water-cooled air compressors, high-temperature shutdown is typically caused by scaling and blockages in the copper cooling tubes, reducing heat transfer efficiency. The maximum design ambient temperature for the air compressor is 45°C. The higher the ambient temperature, the higher the air temperature is discharged. Therefore, it is necessary to choose a location with a relatively low ambient temperature and good ventilation to place the air compressor.

After an automatic protection shutdown occurs due to excessively high exhaust temperature, the system cannot be restarted immediately. The cause must be accurately identified, the fault eliminated, and the fault manually reset before the system can be restarted!

Safety Protection System and Warning Devices

3. Alarm Devices

There are three types of usage time alarm devices in this system: air filter usage time, oil filter usage time, and oil-air separator usage time, all displayed on the control panel. When a filter usage time expiration fault indicator appears on the control panel, it means the filter's service life has been reached.

The user must replace the spare part as quickly as possible; otherwise, it will affect the normal operation and service life of the air compressor.

Control System and Electrical Circuits

1. Control System

1. Motor Start (Reduced Voltage or Y Operation)

During this period, the intake valve is fully closed, and the vent valve is fully open. At this time, the intake side is under high vacuum. The lubricating oil required by the compression chamber and bearings is ensured by the pressure difference between the compression chamber and the oil-air tank.

2. Motor Full Voltage Operation (Full Voltage or Δ Operation)

After the controller switches to full voltage operation, the solenoid valve opens due to being energised, the vent valve closes, and the pressure in the oil-air tank gradually increases. When the pressure in the oil-air tank rises to about 1.5 Bar, the intake valve fully opens, increasing the pressure in the oil tank rapidly, and the compressor begins full-load operation. When the pressure rises to 4.5 – 5.0 Bar, the minimum pressure valve opens automatically, and air can be output.

3. Load/No-Load Operation

When the discharge pressure reaches the upper limit of the system pressure setting, the controller will automatically cut off power to the solenoid valve. The solenoid valve closes, and the intake valve also closes, and simultaneously the vent valve fully opens, discharging the compressed air from the oil-air tank to the atmosphere. At this time, the compressor operates under no-load conditions, and the required lubricating oil is ensured by the pressure difference between the compression chamber and the oil-air tank.

When the pressure in the pipeline system drops to the lower limit of the system setting, the controller will automatically energise the solenoid valve. The solenoid valve opens; the intake valve fully opens; the vent valve closes; and the compressor loads and operates again.

4. Shutdown

After pressing the stop (OFF) button, the solenoid valve de-energises and closes, and simultaneously the vent valve fully opens, discharging the air from the oil-air separator tank to the atmosphere. After about 15 seconds, when the pressure in the oil-air separator tank drops to a specified value, the motor stops.

Control System and Electrical Circuits

5. Emergency Stop

When the exhaust temperature exceeds 110°C or the motor's overcurrent protection device activates due to overload, power will be cut off, and the motor will stop immediately.

Simultaneously, the solenoid valve and intake valve also close, and the vent valve fully opens.

The emergency stop button should be pressed only when abnormal conditions occur during unit operation; otherwise, it may cause a system malfunction.

6. Automatic Shutdown After Prolonged No-Load Operation

If the system's compressed air consumption decreases, the compressor continues to operate under no-load conditions. If the no-load operation time exceeds the set time, the air compressor will automatically shut down, and the motor will stop. When the system's air consumption increases and the system pressure decreases, the air compressor automatically starts supplying additional air volume. The time setting limit for shutdown after prolonged no-load operation is based on the principle that the motor should not start more than twice per hour. The customer can set this according to their usage conditions.

Excessive motor start frequency will shorten its service life and may even burn it out.

2. Electrical Circuits

1. Screw Air Compressor Electrical Circuit

The electrical control of the air compressor can be divided into two systems: the internal control system and the starter panel. The starter panel is a commonly used Y- Δ starting control for general machinery. The control part is electronic. As the internal circuitry and control of the electronic control part are relatively complex, they will not be discussed in depth in this chapter. If damaged or faulty, please contact our company's service units directly.

2. Variable Frequency Screw Air Compressor Electrical Circuit

The electrical system consists of an inverter, main motor, fan motor, electrical control cabinet, solenoid valves, temperature sensors, pressure transmitters, microcomputer controller, operation panel, and other components. **For parameter settings and operation of the frequency conversion compressor, refer to the "User Manual".**

Control System and Electrical Circuits

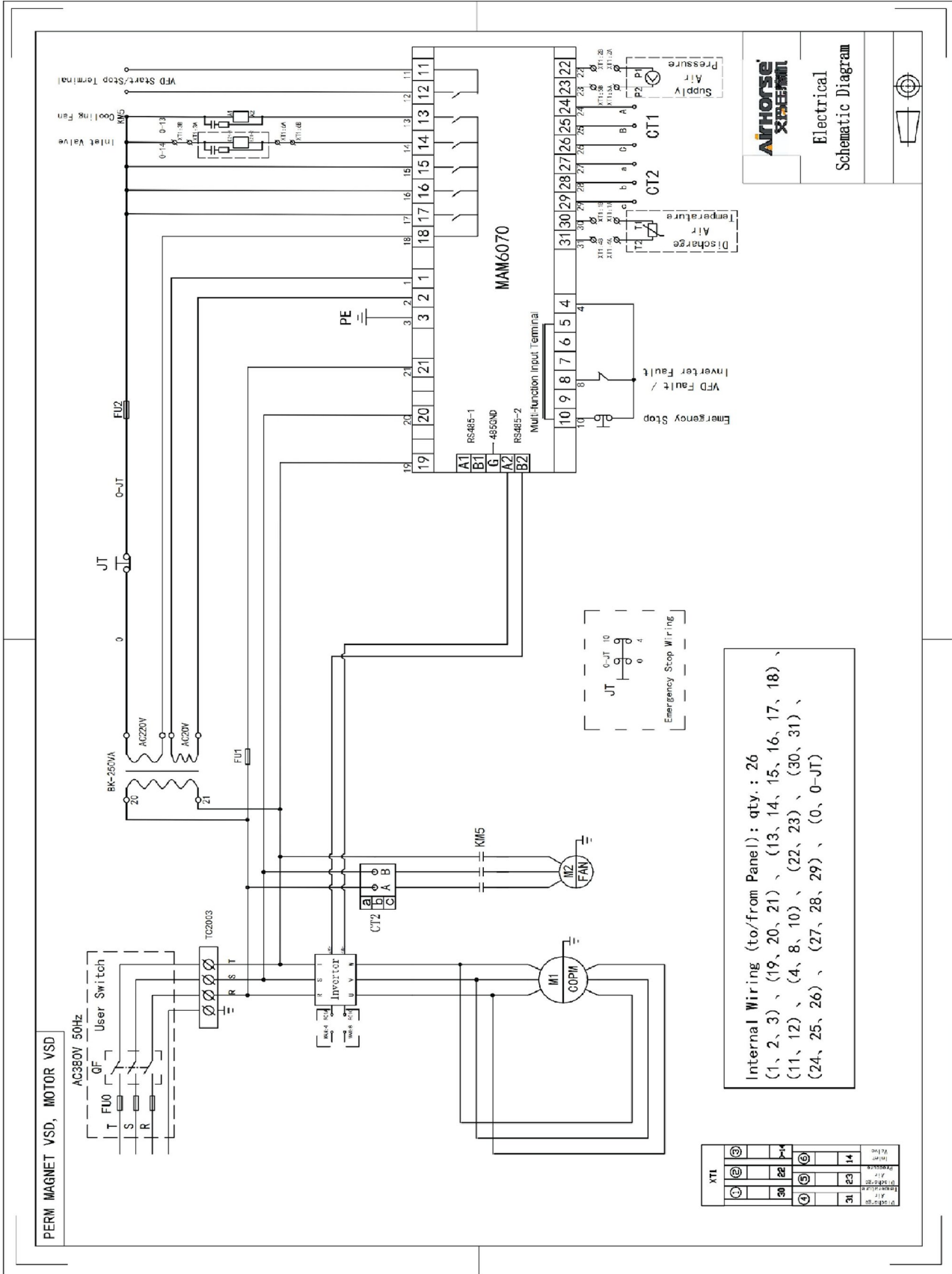

Control System and Electrical Circuits

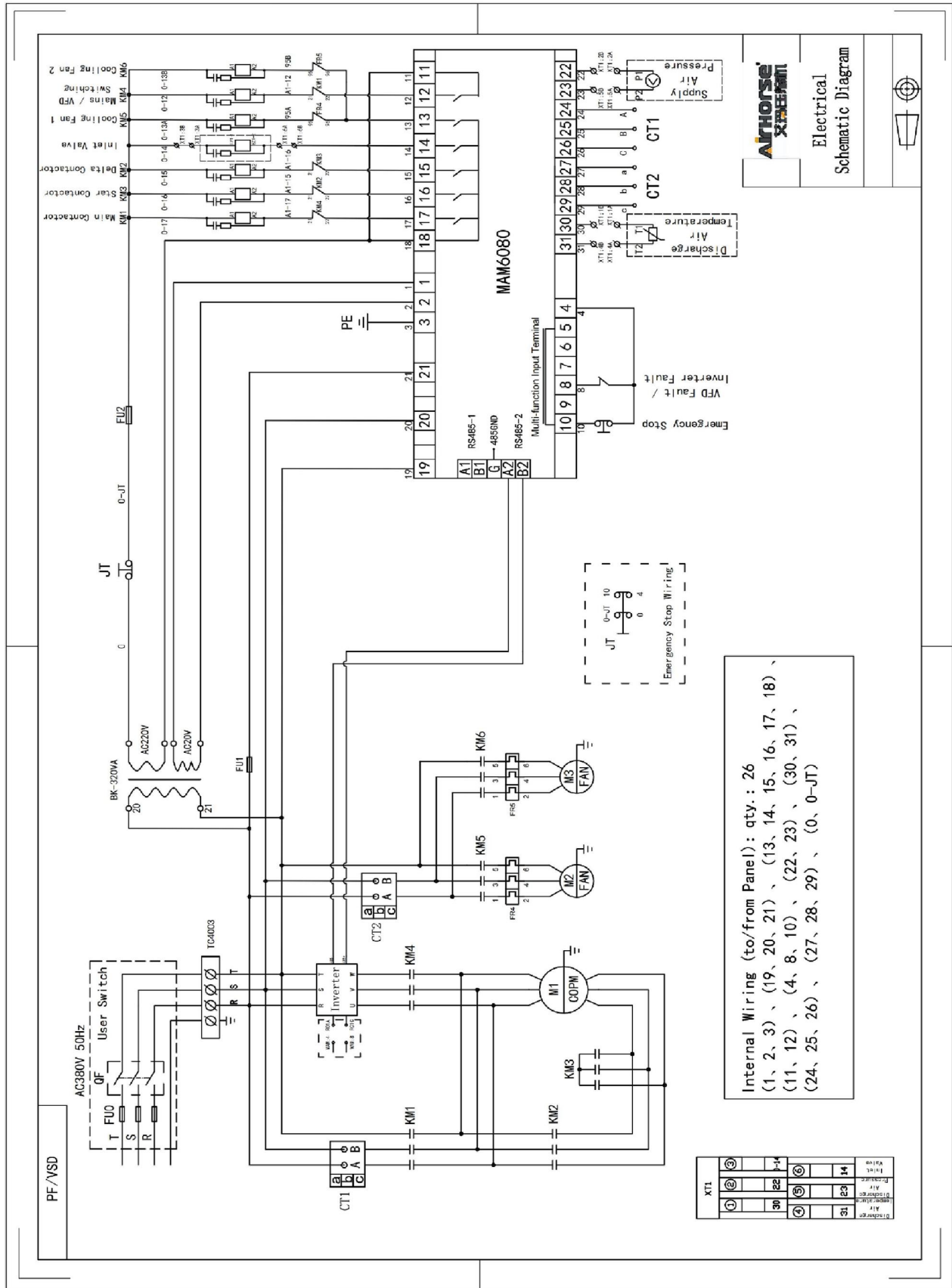

Chapter 4 Controller Basic Operation – MAM 6070 and 6080

1. Button Explanation

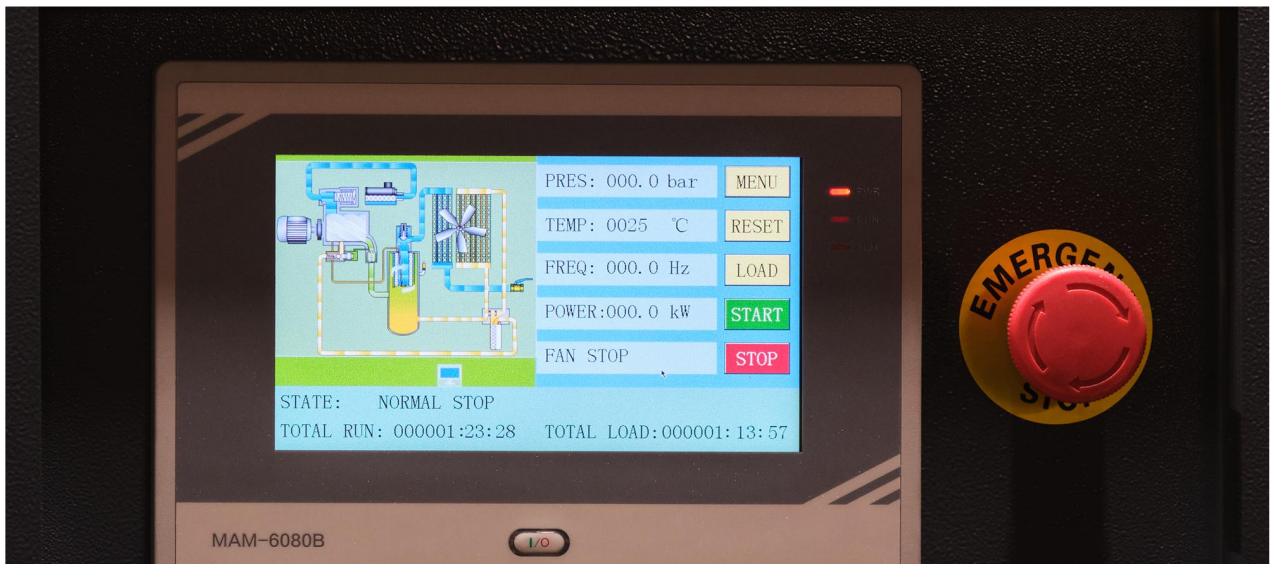

This controller is touch screen.

Start/Stop Button:

 Press and hold to start the compressor

 Press and hold to stop the compressor

The emergency stop button is to only be used during an emergency. It is not to be used to regularly stop the compressor. Use the above stop button for this.

Load / unload Button:

When the compressor is at running status, press this button to load or unload;

Return button / Reset button:

When the controller is at alarm and stop status, press this button for 5s to reset.

2. Indicator explanation

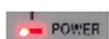

Power

Indicator is alight when controller is powered on



Run

Indicator is alight when motor is running

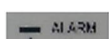

Alarm

Indicator is blinking when controller is alarming;

Indicator is alight when compressor is alarm and stop;

Indicator is of after error is cleared and reset.

Chapter 4 Controller Basic Operation – MAM 6070 and 6080

3. Status Display and Operation

The display screen will show as below after power on and display “MAM-6080” for a while:



After 5 seconds, the menu will switch as below:

The screenshot shows the MAM-6080 controller display. On the left is a schematic diagram of a control system. On the right, the display shows the following data and controls:

- PRES: 00.17 MPa
- TEMP: 00.99 °C
- CURR: 000.0 A
- VOLT: 000 V
- FAN STOP
- TOTAL LOAD: 000014: 59:52
- Buttons: MENU, RESTART, START, STOP

Below the schematic, several icons are shown with callouts explaining their functions:

- This icon means scheduled on/off function is activated
- This icon means auto restart function is activated
- This icon means block function is activated
- This icon means scheduled P function is activated
- This icon means remote function is activated
- This icon means computer

A note on the right side of the screen states: "To prevent interference, it will take 0.2S to take effect after press start or stop icon"

Chapter 4 Controller Basic Operation – MAM 6070 and 6080

Users can enter the menu below through clicking MENU icons on the screen.

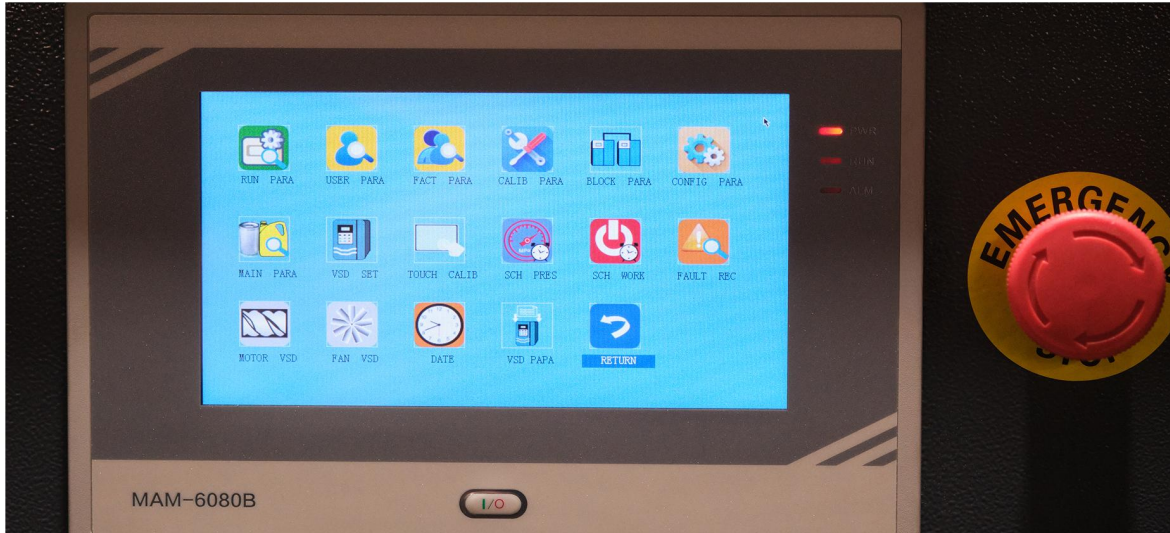

This controller is touch screen.

RUN PARA:

This menu provides compressor information including:

- Oil Run time – How many hours the oil filter has completed
- O-A Run time – How many hours the oil – air separator has completed
- Air Run time – how many hours the air filter has completed
- Lube Run time – how many hours the machine oil has completed
- Grease Run time – how many hours the motor bearing grease has completed Power – voltage connected
- Motor RPM - Motor frequency
- Motor current
- Motor This Elec – how much power has been consumed this session in kwh – Motor Total Elec – how much power has been consumed in total life.

SCH PRES

This allows the scheduling of different pressures at different times of the day

SCH WORK

This allows setting the start and stop times of the compressor each day of the week. For example, you can set the compressor to turn on each morning at 7am, and shut off at 5pm each day. Or have it completely off on the weekend.

FAULT REC

This provides a record of any faults/alarms that occur

**Note for GREG/BD* The other menu's are for compressor experts/service agents and so in this customer manual I don't want to go into detail. Thoughts on how we indicate that, or do we just leave them out?*

Also these pictures aren't great here but when I open them up in windows they are clear. It isn't until I cop them over to word that they get that cross hatching effect. Maybe your graphics team can fix that. And all the formatting/design of this document is rubbish as it is.

Chapter 5: Operation

1. Trial Run, Startup, and Shutdown

1. Connect the power cables and ground wire. Test that the main voltage is correct and that the three-phase power supply is functioning properly.
2. Check that the oil level in the oil tank is between the H (High) and L (Low) marks.
3. If starting the trial run long after delivery, add approximately 0.5 litres of lubricating oil through the intake valve and manually rotate the compressor several turns. This prevents damage to the compressor body from an oil shortage upon startup. Take special care not to allow foreign objects to enter the compressor body to avoid damage.
4. Check the cooling system.
5. Press "START". Within the first few seconds of starting, press the "EMERGENCY STOP" button to check if the rotation direction is correct (refer to the arrow direction). If the rotation is incorrect, swap any two of the three-phase power wires.
6. Press "START" again. The air compressor begins operation.
7. Observe if the control panel indicators are normal. If there are abnormal noises, vibrations, or oil leaks, immediately press "EMERGENCY STOP", shut down, and investigate the cause.
8. Keep the exhaust temperature between 60°C and 100°C.
9. After pressing the "OFF" button, the timing relay activates after 10-15 seconds, and then the motor stops. This prevents the compressor from stopping directly under heavy load conditions.
10. When the "STOP" button is pressed, the vent valve automatically releases air.

2. Pre-Startup Checks

Performing these checks before startup is an essential preliminary work to avoid major compressor failures and improve operational efficiency.

1. Open the manual drain valves on the oil tank and water separator to discharge condensate that accumulated during shutdown. Neglecting this will shorten the lubricating oil's service life and can easily cause bearing burnout.
2. Check that the oil level is between H and L. The oil level should not be too high or too low. Replenish promptly if insufficient.

Do not mix lubricating oils of different brands.

Before adding oil, ensure the system is completely depressurised and the oil filler cap is open.

3. Observe the oil level during operation. Under normal operation, the oil level should be between the high and low limits.

Chapter 5: Operation

3. Precautions During Operation

- 1) If abnormal noises or unusual vibrations occur during operation, stop the machine immediately.
2. During operation, the piping system and internal vessels are pressurised. Do not loosen pipes or plugs, or open unnecessary valves.
3. If the oil level becomes invisible in the sight glass during prolonged operation and the exhaust temperature is too high, stop the machine immediately. After venting all pressure from the system, replenish the lubricating oil.
4. Condensate will accumulate in the after-cooler and cyclone separator during long operation periods. Drain them daily or install an automatic drain valve. Otherwise, the compressed air system will contain some condensate.
5. During operation, check and record parameters displayed on the control panel (voltage, current, air pressure, exhaust temperature, oil level, etc.) every 2 hours for future maintenance reference.

4. Handling Method for Long-Term Shutdown

If the compressor is shut down for an extended period, handle it carefully using the following methods, especially in seasons or areas with high humidity.

1. Shutdown for more than 3 weeks:
 - Wrap electrical equipment, such as the motor control panel, with plastic or oiled paper to prevent moisture ingress, or place desiccant inside.
 - Completely drain the water from the oil cooler and after-cooler.
 - Take the opportunity to rectify any existing faults to facilitate future reuse.
 - Drain the condensate from the oil-gas tank, oil cooler, and after-cooler again after a few days.
2. Shutdown for more than 2 months:
 - In addition to the above procedures, also perform the following:
 - Seal all openings to prevent moisture, dust, and other foreign matter from entering.
 - Wrap the safety valve, electrical control panel, etc., with oiled paper or similar material to prevent corrosion.
 - Before shutdown, replace the lubricating oil and run the compressor for thirty minutes. Drain the condensate from the oil tank and oil cooler again after two or three days.
 - Completely drain the cooling water.
 - If possible, move the machine to a low-dust, dry storage location.
2. Restart Procedure after Long Shutdown:
 - Remove the plastic or oiled paper from the unit.
 - Measure the three-phase insulation resistance of the motor; it should be above 1 MΩ. 3)
 - Follow the other steps as described in the "Trial Run" section.

Chapter 6: Maintenance and Inspection

1. Precautions During Operation

1. Please use Pilot Air Screw Compressor Synthetic Oil 46
2. Oil Change Procedure:
 - Run the air compressor to raise the oil temperature, facilitating drainage. Then press the OFF button to stop the operation.
 - Open the oil drain valve. If pressure is present, drainage will be fast but may spray out. Open slowly to avoid oil splashing.
 - After all oil is drained, close the oil drain valve, open the oil filler cap, and add new oil.

Note: All lubricating oil must be drained from the system, including from pipelines, the cooler, and the oil tank. Add new oil.

2. Pressure System Adjustment

1. System Pressure Adjustment:

Pressure adjustment is performed via the keypad on the microcomputer controller. Two pressure points are displayed (values can be set via the keypad): one is the Unloading Pressure (upper limit), where the compressor unloads when pressure rises to this value; the other is the Loading Pressure (lower limit), where the machine automatically loads when system pressure drops to this value after unloading, causing pressure to rise. Within the maximum pressure allowed by the model's design, both pressure points can be adjusted according to on-site usage conditions.

Chapter 6: Maintenance and Inspection

Item No.	1	2	3	4	5	6	7	8	9	10	11	12	13	14	15	16	17	18	19	20	21	
Part		Oil Filter	Air Filter		O-Ring		Drive Motor Bearings	Fan Motor Bearings		Cooler	Connections/Fittings		Belts	Pulley	Temperature	Pressure Gauge	Pressure Sensor	Electrical Components	Instrument	MPV		
Time																						
1000hr	○	○	○							△		√	√	√	√	√		√	√		△	
2000hr	○	○	○							△		√	√	√	√	√		√	√		△	
3000hr	○	○	○							△		√	√	√	√	√		√	√		△	
4000hr	○	○	○	○			*	*	√	△	△	√	√	√	√	√		√	√	√	√	
5000hr	○	○	○							△		√	√	√	√	√		√	√		△	
6000hr	○	○	○		○					△		√	√	√	√	√		√	√		△	
7000hr	○	○	○							△		√	√	√	√	√		√	√		△	
8000hr	○	○	○	○			*	*	√	△	△	√	√	√	√	√	√	√	√	√	√	
9000hr	○	○	○							△		√	√	√	√	√		√	√		△	
10000hr	○	○	○							△		√	○	√	√	√		√	√		△	
11000hr	○	○	○							△		√	√	√	√	√		√	√		△	
12000hr	○	○	○	○	○		*	*	√	△	△	√	√	√	√	√		√	√	√	√	

Chapter 6: Maintenance and Inspection

13000hr	○	○	○							△		√	√	√	√	√		√	√		△
14000hr	○	○	○							△		√	√	√	√	√		√	√		△
15000hr	○	○	○							△		√	√	√	√	√		√	√		△
16000hr	○	○	○	○			*	*	√	△	△	√	√	√	√	√	√	√	√	√	○

3. Recommended Maintenance Schedule

Legend: ○ = Replace √ = Inspect/Check △ = Clean * = Add Lubricant/Grease

Item No.	1	2	3	4	5	6	7	8	9	10	11	12	13	14	15	16	17	18	19	20	21	
Part		Oil Filter	Air Filter		O-Ring		Drive Motor Bearings	Fan Motor Bearings		Cooler	Connections/Fittings		Belts	Pulley	Temperature	Pressure Gauge	Pressure Sensor	Electrical Components	Instrument	MPV		
Time																						
17000hr	○	○	○							△		√	√	√	√	√		√	√		△	
18000hr	○	○	○	○						△		√	√	√	√	√		√	√		△	
19000hr	○	○	○							△		√	√	√	√	√		√	√		△	
20000hr	○	○	○	○			*	*	√	△	△	√	○	√	√	√		√	√	√	√	
21000hr	○	○	○							△		√	√	√	√	√		√	√		△	
22000hr	○	○	○							△		√	√	√	√	√		√	√		△	

Chapter 6: Maintenance and Inspection

23000hr	○	○	○						△		√	√	√	√	√		√	√		△	
24000hr	○	○	○	○	○		○	○	√	△	△	√	√	√	√	√	√	√	√	√	
25000hr	○	○	○							△		√	√	√	√	√		√	√		△
26000hr	○	○	○							△		√	√	√	√	√		√	√		△
27000hr	○	○	○							△		√	√	√	√	√		√	√		△
28000hr	○	○	○	○			*	*	√	△	△	√	√	√	√	√		√	√	√	√
29000hr	○	○	○							△		√	√	√	√	√		√	√		△
30000hr	○	○	○		○					△		√	○	√	√	√		√	√		△
31000hr	○	○	○							△		√	√	√	√	√		√	√		△
32000hr	○	○	○	○			*	*	√	△	△	√	√	√	√	√	√	√	√	√	○

Legend: ○ = Replace √ = Inspect/Check △ = Clean * = Add Lubricant/Grease

1. This maintenance schedule is provided for user reference. The maintenance intervals for new products and components depend heavily on the compressor's operating environment. Poor environments may lead to shorter consumable life or component failure. In good environments, replacement intervals can be extended to every 2000 hours. (Screw Air Compressor Synthetic 46 Oil).
2. This maintenance list is in addition to your company's routine daily maintenance items, such as checking oil levels, recording pressure gauge readings and operating oil temperature.

Chapter 7: Troubleshooting

1. Troubleshooting Guide

Item	Fault Condition	Possible Causes	Corrective Actions
1	Failure to Start (Electrical Fault Light On)	<ol style="list-style-type: none"> 1. Fuse blown 2. Protection relays faulty 3. Start relay faulty 4. Start button has poor contact 5. Voltage too low 6. Motor fault 7. Compressor element fault 8. Phase loss protection relay fault 	<ol style="list-style-type: none"> 1. Replace the fuse. 2. Replace the protection relay. 3. Replace the start relay. 4. Have an electrician check/replace. 5. Have an electrician check the power supply. 6. Have an electrician check/replace the motor. 7. Manually rotate the element. If it doesn't turn, contact our service department. 8. Check power cables and connections.
2	Displays Y-Δ Start but Unit Doesn't Run	The emergency stop switch is faulty Control circuit fault or loose wire	<ol style="list-style-type: none"> 1. Replace component. 2. Have an electrician check/replace.
3	High Operating Current, Auto Shutdown (Electrical Fault Light On)	<ol style="list-style-type: none"> 1. Voltage too low 2. Discharge pressure is too high 3. Incorrect lubricant specification 4. Loose belt drive 5. Oil-gas separator blocked (high oil pressure) 6. Compressor element fault 	<ol style="list-style-type: none"> 1. Check the power supply system. 2. Check pressure. If it exceeds the set point, check the settings & pressure sensor. 3. Check oil type, replace oil. 4. Check and adjust tension. 5. Replace the oil-gas separator. 6. Manually rotate the element. If it doesn't turn, contact our service department.
4	Operating Current Lower Than Normal	<ol style="list-style-type: none"> 1. Air consumption too high (running below set pressure) 2. Air filter blocked 3. Intake valve malfunction (butterfly valve stuck) 4. Capacity regulation valve improperly adjusted 	<ol style="list-style-type: none"> 1. Check consumption, add a compressor if needed. 2. Clean or replace. 3. Dismantle, clean, and lubricate. 4. Readjust/Reset.

Chapter 7: Troubleshooting

1. Troubleshooting Guide

5	Exhaust Temperature Lower Than Normal (Below 75°C)	<ol style="list-style-type: none"> 1. Cooling water flows too high 2. Low ambient temperature 3. No-load operation too long 4. Temperature sensor deviation 5. Thermostatic valve fault 	<ol style="list-style-type: none"> 1. Adjust the cooling water outlet valve. For air-cooled, reduce the cooler surface area. 2. Adjust the cooling water outlet valve. For air-cooled, reduce cooler surface area. 3. Reset high-pressure shutdown timer. 4. Replace the temperature sensor. 5. Replace the thermostatic valve.
6	High Exhaust Temp, Auto Shutdown, Fault Display (Exceeds 100°C set point)	<ol style="list-style-type: none"> 1. Insufficient lubricant 2. Insufficient cooling water 3. High cooling water temperature 4. High ambient temperature 5. Oil cooler blocked 6. Incorrect lubricant specification 7. Thermostatic valve fault 8. Dirty air filter 9. Oil filter blocked 10. Cooling fan fault 	<ol style="list-style-type: none"> 1. Check oil level, stop and add oil if below "L". 2. Check the difference in inlet/outlet water temperatures. 3. Check inlet water temperature. 4. Increase ventilation, reduce room temp. 5. Check oil line temp difference (~5°C normal). If lower, cooler may be blocked; remove and clean with a chemical. 6. Check oil type, replace oil. 7. Check if oil passes through the oil cooler. If not, replace the thermostatic valve. 8. Clean the air filter with low-pressure air. 9. Replace the oil filter. 10. Replace the cooling fan.
7	High Oil Content in Air, Shortened Oil Top-up Intervals, Filter Smokes at No-load	<ol style="list-style-type: none"> 1. Oil level is too high 2. Oil return orifice blocked 3. Low discharge pressure 4. Intake valve check function failed 5. Oil-gas separator damaged 6. Minimum pressure valve spring fatigue 7. Oil return check valve fault 8. Incorrect lubricant specification 	<ol style="list-style-type: none"> 1. Check oil level, drain between "H" & "L". 2. Dismantle and clean. 3. Check discharge pressure, adjust if needed. 4. Check the intake valve; replace if necessary. 5. Replace with the new part. 6. Replace the spring. 7. Replace with the new part. 8. Check oil type, replace oil.

Chapter 7: Troubleshooting

1. Troubleshooting Guide

8	Cannot Unload, Pressure Remains / Rises at No-load, Safety Valve Activates	<ol style="list-style-type: none"> 1. Pressure sensor failure 2. Intake valve malfunction 3. Solenoid vent valve failure (coil burnt) 4. Capacity regulation diaphragm damaged / orifice too small 	<ol style="list-style-type: none"> 1. Check/Repair, replace if necessary. 2. Dismantle, clean, and lubricate. 3. Check/Repair, replace if necessary. 4. Check/Repair/Replace, enlarge orifice appropriately.
9	Cannot Reach Full Load	<ol style="list-style-type: none"> 1. Pressure sensor fault 2. Three-phase solenoid valve fault 3. Intelligent controller fault 4. Time delay relay fault 5. Intake valve malfunction 6. Minimum pressure valve malfunction 7. Proportional valve fault 8. Intake valve servo cylinder blocked 9. Water separator cup leaking air 10. Control line leak 	<ol style="list-style-type: none"> 1. Replace pressure sensor. 2. Replace three-phase solenoid valve. 3. Replace intelligent controller. 4. Replace time delay relay. 5. Dismantle, clean, and lubricate. 6. Dismantle, check valve seat & check ring for wear, replace. 7. Check nozzle & proportional valve for blockage. 8. Check, dismantle and clean. 9. Check if water separator cup leaks continuously. 10. Check leak location and tighten.
10	Compressor Air Output Lower Than Normal	<ol style="list-style-type: none"> 1. Intake filter blocked 2. Intake valve malfunction 3. Minimum pressure valve malfunction 4. Oil-gas separator blocked 5. Vent valve leaking 6. Intake proportional valve setting error 	<ol style="list-style-type: none"> 1. Clean or replace. 2. Dismantle, clean, and lubricate. 3. Dismantle, check valve seat & check ring for wear/spring fatigue, replace. 4. Check/Repair, replace if necessary. 5. Check/Repair, replace if necessary. 6. Check/Repair, replace if necessary.
11	Frequent Load/Unload Cycling	<ol style="list-style-type: none"> 1. Pipeline leak 2. Pressure differential setting too small 3. Unstable air consumption 	<ol style="list-style-type: none"> 1. Check leak location and seal/tighten. 2. Reset (typically 0.1 MPa differential). 3. Increase air receiver capacity.

Chapter 7: Troubleshooting

1. Troubleshooting Guide

12	Oil Mist from Air Filter when Stopping	<ol style="list-style-type: none">1. Intake valve leaking2. Stopped under load3. Three-way solenoid valve malfunction4. Electrical wiring error5. Minimum pressure valve leaking6. Vent valve not venting	<ol style="list-style-type: none">1. Check/Repair, replace if necessary.2. Check if intake valve stuck; if so, dismantle, clean, lubricate.3. Check, replace if necessary.4. Have electrician check/correct wiring.5. Check/Repair, replace if necessary.6. Check vent valve, replace if necessary.
----	--	--	--

Chapter 7: Troubleshooting

2. Screw Air Compressor Operation Log Sheet

Year _____ Month _____

Date								
Item								
1、Oil-Gas Tank Oil Level								
2、Air Filter Indicator								
3、Oil Filter Indicator								
4、Oil Separator Indicator								
5、Operating Current (A)								
6、Operating Voltage (V)								
7、Discharge Pressure (kg/cm ²)								
8、Exhaust Temperature (°C)								
9、Operating Hours (Hour)								
Recorder								
Remarks								

Chapter 8: Spare Parts

How to order spare parts?

You must order from our company or authorised distributors to guarantee genuine, high-quality spare parts.

You should provide the following information:

Machine Model, Machine Manufacturing Date, Serial Number, Name, and Quantity.

Tip: To ensure maximum compressor utilisation, it is recommended to keep an adequate stock of spare parts

(See table below)

Part Name	Replacement Cycle	Remarks
Screw Air Compressor Special Oil	Every 1000H	Lubricant Oil Synthetic 46.
Oil Filter	Every 1000H	Replace after every 1000H of operation.
Air Filter	Every 1000H	Replace after every 1000H of operation
Oil-Air Separator	Every 3000-4000H	Monitor oil pressure vs outlet air pressure differential. Replace immediately if the differential reaches 1.0 Bar.
Special Belts	According to usage condition	
Coupling	According to usage condition	
Pressure Sensor	According to usage condition	
Temperature Sensor	According to usage condition	
Control Solenoid Valve	According to usage condition	
AC Contactor	According to usage condition	Check contacts at 4000H (clean), replace at 16000H.
Minimum Pressure Valve	According to usage condition	Check seals at 4000H, then replace seals according to usage condition.
Intake Valve	According to usage condition	Check solenoid seal at 4000H (clean), then seals according to usage condition.

Note: Depending on environmental conditions, replacement intervals can be extended to every 2000 hours of total running in very good environments.

Chapter 9: Warranty Terms and Conditions

Pilot Air Compressors Pty Ltd manufactured goods - 1 Year Warranty and 3 Year Warranty (where applicable)

March 2026

Pilot Air Compressors Pty Ltd (Pilot Air) warrants to the first purchaser of goods (manufactured by it) (Product) from Pilot Air and the last purchaser prior to installation that, subject to compliance with the Conditions of Warranties below, that:

1. For a period of 12 months from the date of purchase, the Product will be free from defects due to defective factory workmanship or materials; and
2. For a period of 12 months from the date of purchase, Pilot Air-branded accessories supplied by Pilot Air will be free from defects due to defective factory workmanship or materials.
3. The compressor pump only (and excluding all other components of the unit) in the following units:
 - TM Series Units
 - Professional K11/K17 Unitswill be free from defects due to defective factory workmanship or materials for a period of 3 years from the date of purchase.
4. The compressor pump, receiver tank and platform only (and excluding all other components of the unit) in the following units:
 - Classic K Series Units
 - Petrol Industrial Series Units
 - Diesel Industrial Series Units
 - Three Phase Industrial Series Unitswill be free from defects due to defective factory workmanship or materials for a period of 5 years from the date of purchase. All warranties are subject to recommended servicing being carried out by PilotAir Service or authorised repair agents using genuine PilotAir Spare parts.
5. The 'PAC' and 'ATVS' Series of Rotary Screw type compressors will be free from defects due to defective factory workmanship or materials for 3,000 working hours in the first 12 months from the date of purchase. This warranty extends to 3 years for the air end of PAC and ATVS Series Compressors.
6. Where compressors are powered with either petrol or diesel engines, the engine only is subject to the warranty provided by the manufacturer of the engine.
7. Non-Pilot Air accessories (meaning accessories which are not Pilot Air manufactured and branded), which are supplied by Pilot Air, are not covered by this warranty. Purchasers are referred to the individual manufacturer's warranty. Purchasers can request a copy of the applicable warranties by contacting Pilot Air using the contact details below.
8. The 'NGS VS' Series of Rotary Screw type air compressors will be free from defects due to defective factory workmanship or materials for 6,000 working hours in the first 3 years from the date of purchase. This warranty is also for a period of 3 years for the air end of the 'NGS VS' Series Air Compressors.

Chapter 9: Warranty Terms and Conditions

Conditions of Warranties

- a. The warranties specified herein are subject to the following conditions:
- b. Pilot Air will not be liable for a breach of any of its warranties unless the Claimant provides proof of purchase of the Product and makes a written claim to Pilot Air at the address set out below, either within 30 days after the defect would have become reasonably apparent, or if the defect was reasonably apparent prior to installation, then the claim must be made prior to installation;
- c. The warranties are not transferable.
- d. The Product must be installed, operated, maintained and serviced strictly in accordance with the relevant Pilot Air literature current at the time of installation and must be installed in conjunction with the components or products specified in the Pilot Air literature. To obtain copies of such literature, go to www.pilotair.com.au or telephone Pilot Air on (02) 9648 3099;
- e. If the claimant chooses to rely upon any warranty specified herein the claimant's sole remedy under the warranty for breach of the warranty is (at Pilot Air's option) that Pilot Air will either supply replacement Product, rectify the affected Product or pay for the cost of the replacement or rectification of the affected product;
- f. In the circumstances where the guarantees under the Australian Consumer Law do not apply in respect to the purchase of its Products, Pilot Air will not be liable for any losses or damages (whether direct or indirect), including property damage or personal injury, consequential loss, economic loss or loss of profits, arising in contract or negligence or howsoever arising. Without limiting the foregoing, Pilot Air will not be liable for any claims, damages or defects arising from misuse of the Product, inadequate maintenance and storage of the Product, repairs rendered necessary or arising from the use of non-genuine Pilot Air parts in the product, normal wear and tear maintenance of the Product, deterioration of any part of the Product due to normal wear and tear, work performed on the Product other than by an authorised Pilot Air service technician or their agent, use of the Product for any purpose other than which it was intended to be used, use of the Product after essential parts and accessories have been removed, operating the Product continuously under excessive load, and if the serial/model label has been removed or obscured on the Product;
- g. In circumstances where the guarantees under the Australian Consumer Law do not apply in respect to the purchase of its Product/s: all warranties, conditions, liabilities and obligations other than those specified herein are excluded to the fullest extent allowed by law.
- h. Parts repaired or replaced under any warranty specified herein are warranted only for the remaining period of the original warranty period.
- i. All defective parts that are the subject of a claim under any warranty specified herein become the property of Pilot Air.
- j. The warranties specified herein do not apply to the following parts or conditions, and cannot be relied upon in the situation whereby:
 - i. Any Pilot Air product or part has been subject to misuse, negligence, accidental damage, improper or inadequate use, inadequate maintenance, improper storage or been operated under unusual conditions or continuously under excessive load;
 - ii. The defect has been caused by the use of non-genuine Pilot Air parts;
 - iii. the defect or deterioration was due to normal use, fair wear and tear and exposure, unless due to any defect in material or workmanship;
 - iv. work was undertaken on any Pilot Air product or part by an unauthorised Pilot Air agent;
 - v. The serial /model label has been removed from any Pilot Air product or part;
 - vi. normal maintenance items/parts, including valves and piston rings

Chapter 9: Warranty Terms and Conditions

Conditions of Warranties

- k. Warranty repairs on all 240 Volt and portable units shall be on a back to base basis, that the Claimant is required to return the Product to the nominated warranty agent as advised by Pilot Air, provided that such costs are not significant.
- l. The replacement or repair of any defective part, or the correction of operating faults, under any warranty specified herein is to be made only after Pilot Air, or its authorised representative, has examined the unit to their satisfaction, with their decision being final.
- m. In the circumstances where Pilot Air accepts or it is determined by Pilot Air that the claimant has a valid claim under this warranty, and subject to paragraph (m) below, Pilot Air will bear all of the claimant's reasonable and proximate expenses incurred as a result of claiming under this warranty. The claimant is to inform Pilot Air in writing to the address identified below within 21 days from when the claimant first makes a claim under this warranty of all such claims and expenses, and provide it with copies of all receipts and invoices where relevant before any reimbursement is made by Pilot Air to the claimant. The claimant is responsible for all other costs associated with this warranty claim.

Important Note:

If you acquire goods from Pilot Air as a consumer according to the Australian Consumer Law, our goods come with guarantees that cannot be excluded under the Australian Consumer Law. You are entitled to a replacement or refund for a major failure and for compensation for any other reasonably foreseeable loss or damage. You are also entitled to have the goods repaired or replaced if the goods fail to be of acceptable quality and the failure does not amount to a major failure.

Any rights a consumer may have under any warranty specified herein are in addition to other rights and remedies of a consumer under a law in relation to the goods to which these warranties relate. Nothing in this document shall exclude or modify any legal rights a customer may have under the Australian Consumer Law or otherwise, which cannot be excluded or modified at law.

Contact details if you wish to make a claim under any warranty specified herein:

For more information or to make a claim under any warranty specified herein, please telephone Pilot Air on 1300 667 579, email Pilot Air via our website: <http://www.pilotair.com.au> or write to Pilot Air at:

Pilot Air Compressors Pty Ltd
115 Beaconsfield St
Silverwater NSW 2128